

Special For DC-AC Rectifier Bridge

Features

- Compliant with RoHS Provisions
- Low forward voltage, high forward current
- High forward surge current capability
- High heat-conducting performance
- Thermal welding performance:
260 °C/10sec

Applications

- Switching Power Supply
- Home Appliances, Office Devices
- Industrial Auto-equipments

PINNING

PIN	DESCRIPTION
1	Input Pin (~)
2	Input Pin (~)
3	Output Anode (+)
4	Output Cathode (-)

	V_{RRM}		V
Maximum RMS voltage	V_{RMS}		V
Maximum DC Blocking Voltage	V_{DC}		V
Average Rectified Output Current	I_o	10.0	A
Peak Forward Surge Current 8.3 ms Single Half Sine Wave Superimposed on Rated Load(JEDEC Method)	I_{FSM}	200	A
$I^2 t$ rating for fusing (1ms < t < 8.3 ms)			
Maximum Forward Voltage at 5.0 A	V_F	1.25	V
			μA
Junction to ambient without heatsink Junction to case, with heatsink			
Operating and Storage Temperature Range	T_j, T_{stg}	-55 ~ +150	°C

RATINGS AND CHARACTERISTICS CURVES (TA = 25 °C unless otherwise noted)

Fig.1: Current Derating Curve

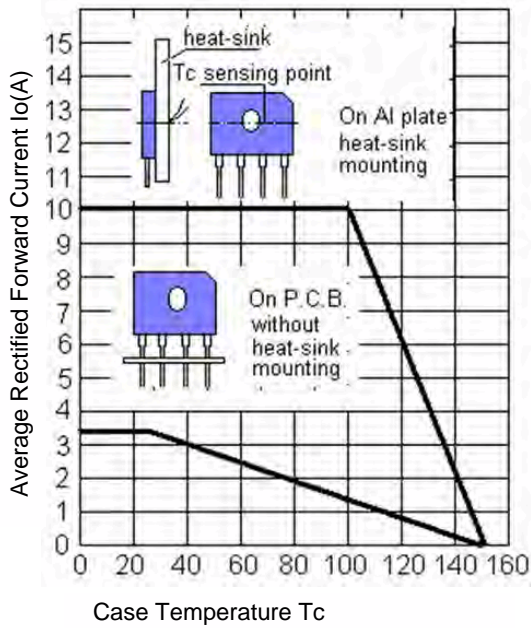

Fig.3: Max. Surge Current

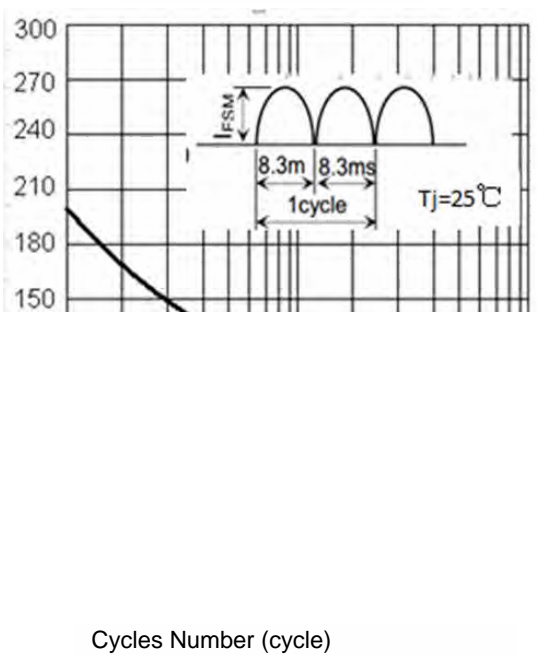

Fig.2 Typical Reverse Characteristics

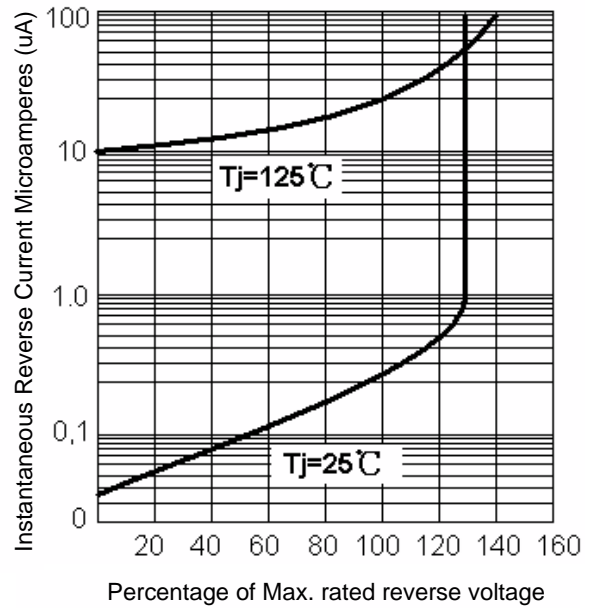

Fig.4: Rated Forward Features

Forward Current I_F A

Forward Voltage V_F V



GBU1006E50

23-NOV-2020

PACKAGE OUTLINE DIMENSIONS

Note:unit mm(inch)

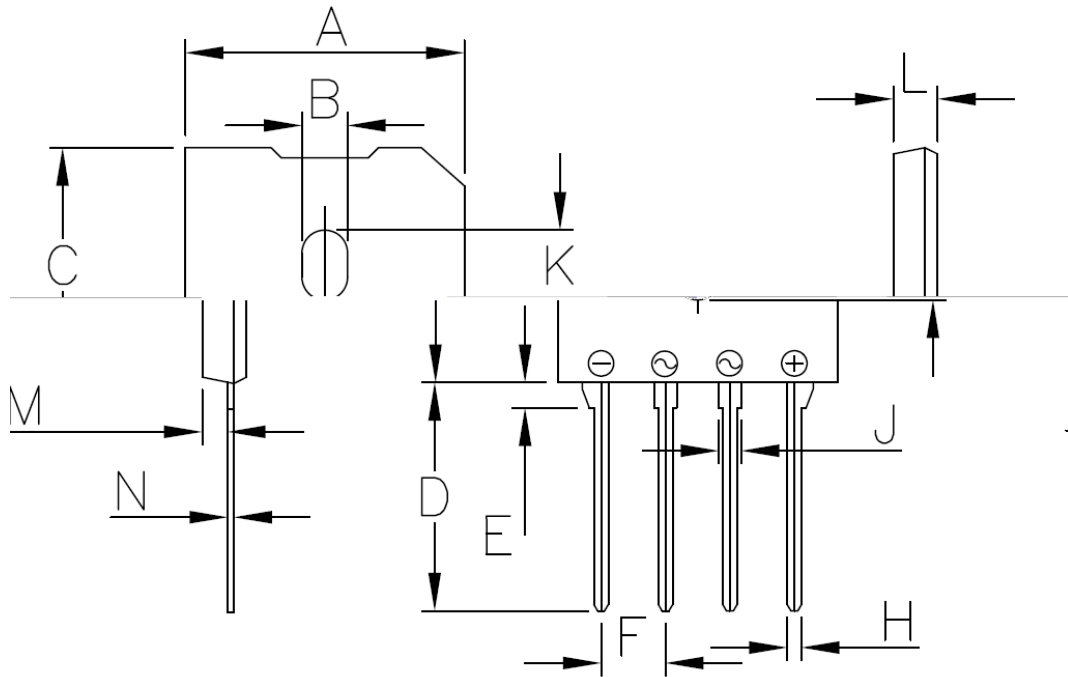

GBU mechanical data: unit mm(inch)

Unit		A	B	C	D	E	F	H	J	K	L	M	N
mm	max	22.3	4.1	18.8	18.5	2.1	5.43	1.15	2.24	5.6	3.6	2.3	0.6
	min	21.7	3.5	18.2	17.5	1.5	4.73	0.85	1.64	5.1	3.2	1.8	0.4
inch	max	0.88	0.17	0.74	0.73	0.09	0.22	0.045	0.09	0.22	0.15	0.09	0.03
	min	0.85	0.13	0.71	0.68	0.06	0.18	0.033	0.06	0.20	0.12	0.07	0.015

Marking Information

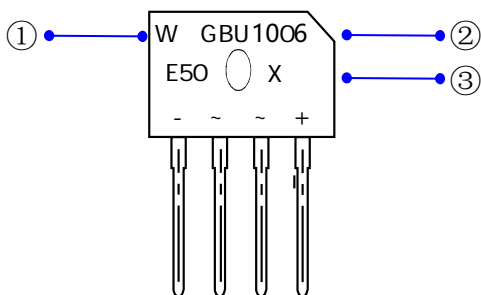

W : Company's trademark

Product model : GB

PDC information

Y X WW

WW:Week code(01 to 53)

X:Internal identification code

Y:Year code(ex:0=2020)